

A Simple Fault Correction Method for Rotor Position Detection of Brushless DC Motor using a Latch Type Hall Effect Sensor

In-Cheol Baik[†] and Hyeong-Gil Joo^{*}

[†]Department of Computer Application Control, Kyonggi Institute of Technology

^{*}Department of Mechatronics Engineering, Korea Polytechnic University

ABSTRACT

A simple fault correction method for rotor position detection of a brushless DC (BLDC) motor with trapezoidal back EMF (electromotive force) using a Hall effect latch unit is presented. The reason why the Hall effect latch unit does not operate properly during the startup of a BLDC motor is thoroughly explained. To solve this problem, a simple code change method and its hardware implementation issues are proposed and discussed.

Keywords: Hall effect sensor, rotor position detection, brushless dc motor, fault correction

1. Introduction

Bipolar latch type Hall effect sensors are widely used for rotor position detection in brushless DC (BLDC) Motors, especially in home appliances. This is due to their simplicity and low cost^[1-2]. In this paper, a BLDC motor with an axial air gap is considered. A BLDC motor is used in air compressor applications, therefore, the rotation of motion is uni-directional. The structure of a BLDC motor is shown in Fig. 1. A BLDC motor has a rotor consisting of three fan cake assemblies including permanent magnets and a stator consisting of two fan cake assemblies of coils including the assembled circuitry of the Hall effect sensor. The outer sides of the two stators are covered with magnetic steel for magnetic paths. A typical magnetic path for one pole pair is shown in Fig. 1. For the detection of

the rotor position, a detailed photograph of the rotor which shows stripped slots on the magnetic steel is shown in Fig. 2. The first half (that is, 90 degrees in electrical angle) of each magnetic pole has a stripped slot on the magnetic steel. The strength of the magnetic flux density on the magnetic steel area is much weaker than that of the stripped slot area. The rotor position detection process using the Hall effect latch sensor for this type of motor can be explained as follows. The bipolar latch type Hall effect

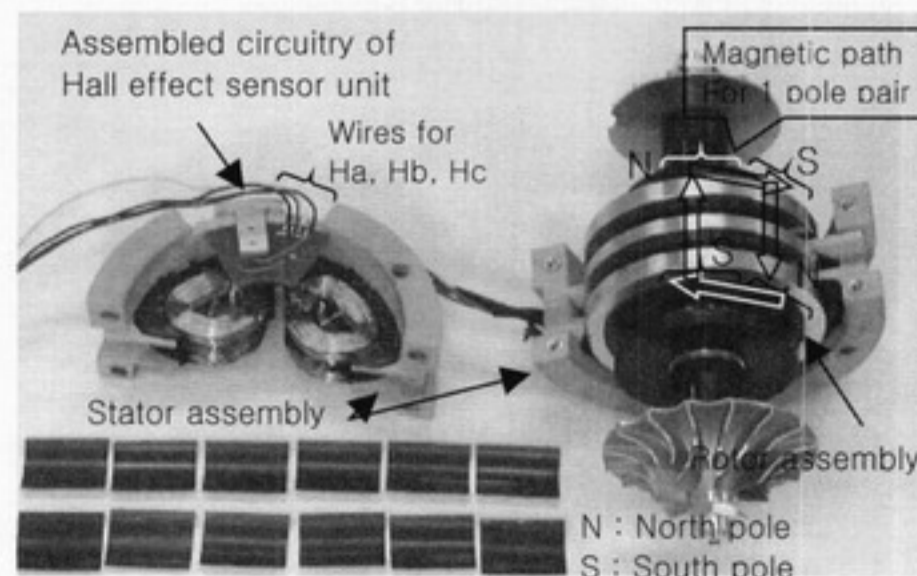

Fig. 1 Photograph of the overall structure of a fan cake Brushless DC Motor with axial air gap

Manuscript received July 30, 2004; revised December 6, 2004.

[†]Corresponding Author: icbaik@kinst.ac.kr, Kyonggi Institute of Tech. Tel: +81-31-496-4773, Fax: +81-31-496-4625

^{*}Dept. of Mechatronics Engineering, Korea Polytechnic Univ.

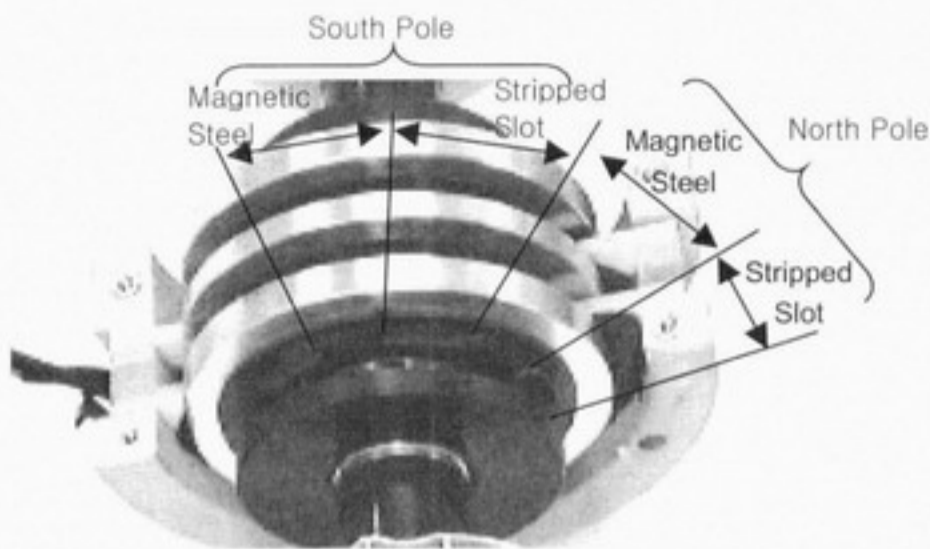

Fig. 2 Detailed photograph which shows stripped slots on the magnetic steel

sensor latches its output state, that is, a south pole of sufficient strength will turn the device on. Removal of the south pole will leave the device on. The presence of a north pole of sufficient strength is required to turn the device off [3]. Since the output stage of the device normally consists of an open collector structure, the off state of the device corresponds to logic high and vice versa. If the final position of the rotor is where the north (or south) pole is removed (so that the sensor output is latched in its previous state) when the control power is turned off, the output of a latch type Hall effect sensor is always logic high (the device is off) at the next starting stage. So, the fault of the rotor position detection can occur during the starting stage of a BLDC motor.

To solve this problem, a simple and practical fault correction method for the rotor position detection Hall effect latch of a BLDC motor is presented.

2. Fault of latch type Hall effect sensor unit in BLDC motor

Consider the typical output waveform of a latch type Hall effect sensor as shown in Fig. 3. Only the first half of each area of logic high results from the effect of the north pole. The rest of the area of logic high results from the latch function of the device, and vice versa for the logic low state. As shown in Fig. 3, the three signals (Ha, Hb, Hc) for phases a, b, and c constitute six codes (100, 110, 111, 011, 001, 000) which represent the rotor position within 60 degrees of electrical angle resolution. The codes

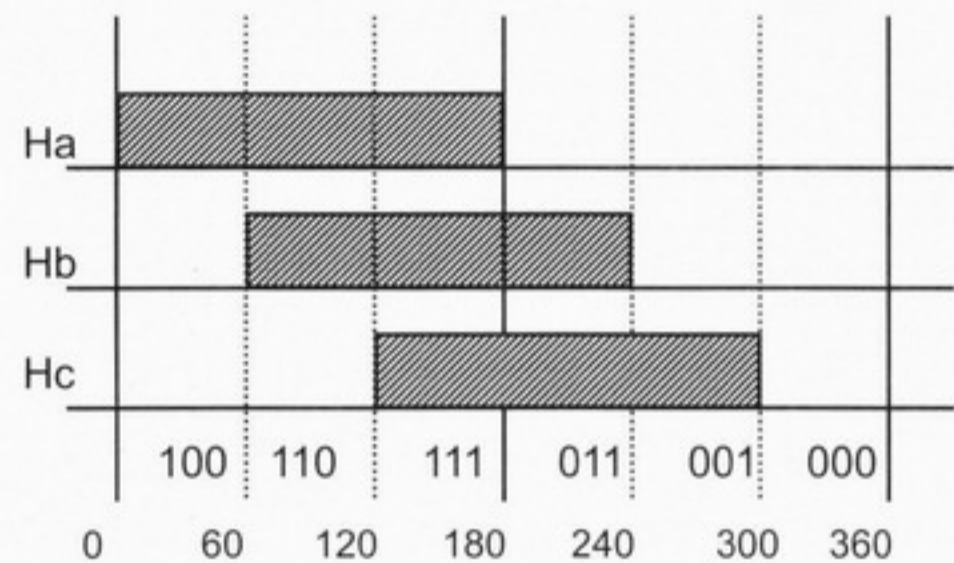

Fig. 3 Output waveforms (Ha, Hb, Hc) of a latch type Hall effect sensor

that represent rotor position are made by simply arranging the three signals (Ha, Hb, Hc) in serial order. The "1" in the code corresponds to logic high, while the "0" in the code corresponds to logic low. Now, let's consider how the faulty detection of the rotor position can occur. We must keep in mind the following three facts.

- 1) The presence of a north pole of sufficient strength is required to turn the device off after the device has been turned on.
- 2) The presence of a south pole of sufficient strength is required to turn the device on after the device has been turned off.
- 3) When the power is turned on after being powered off, the output stage of the device can be turned on if and only if there is a south pole of sufficient strength. If the south pole or north pole are of relatively weak strength, the output stage of the device will be the logic high state because of the open collector structure of the output stage.

If the final position of the rotor is just after the stripped slot area of a north pole, the flux density of a north pole in this area is much weaker than that of the stripped slot area. The output of the sensor unit will be latched in its previous state, logic high. In this case, fortunately, the output of the latch type Hall effect sensor is always logic high whenever the power of the Hall effect sensor is turned on after the power has been turned off, because the output stage of the sensor has an open collector structure.

Unfortunately, in the case of the south pole, the result is quite different. If the final position of the rotor is just after the stripped slot area of a south pole, the flux density of a

south pole in this area is much weaker than that of the stripped slot area. The output of the sensor unit will be latched in its previous state, which is logic low under normal operating conditions. However, when the power to the Hall effect sensor is turned on after the power has been turned off, the output of the latch type Hall effect sensor is logic high because the output stage of the sensor has an open collector structure. It is useful to note that the faulty detection of the rotor position occurs only when the output of the Hall effect sensor latches logic low, that is, when the final position of the rotor is just after the stripped slot area of a south pole at power turn off. Therefore, according to the output of the Hall effect sensor at power turn off, the codes for the rotor position will be incorrect as shown below:

codes in normal operating state		incorrect codes during starting stage
100	→	110 or 111
110	→	111
001	→	101(undefined code)
000	→	100 or 110
111 or 011	→	unchanged

Of the above incorrect codes, code 101 is not defined under normal operating conditions. Therefore, a BLDC motor can not be started successfully. For the other incorrect codes, a BLDC motor may run in reverse or not start at all. On the other hand, codes 111 and 011 in the normal operating state should not be changed whether the power was off or on. The BLDC motor will operate successfully.

3. A simple and practical fault correction method

In order to solve the above mentioned problem, in the starting stage of a BLDC motor, the faulty codes should be changed to other adequate codes (Aa, Ab, Ac) to produce driving torque in the right direction. No analytical method is used to search for the alternate codes. Instead, output waveforms of Hall effect sensors which represent the rotor magnet position of a BLDC motor and a conceptual back EMF (electromotive force) waveform at that position are

used. The alternate codes can be determined by carefully selecting codes which will produce positive torque in the right direction. The alternate codes to produce torque in the right direction were searched for in the advance angles between 0 and 15 degrees in the electrical angle. An advance angle is a relative angle of output waveform of the sensor which is used in advance to the back EMF waveform in order to drive motors at very high speeds. The result of the search is shown below:

incorrect codes		alternate codes
110	→	100
111	→	11X
011	→	011 (unchanged)
101 (undefined code)	→	001
100	→	000

The code change operation itself can be easily implemented using standard combinational logic gates and a multiplexer as shown in the upper half of Fig. 4. However, the code change operation should be executed only once during startup before the normal codes 111 or 011 appear. To execute this important control function, an additional control circuit was designed using logic gates and a bi-stable latch as shown in the lower half of Fig. 4. The required function table for the bi-stable latch of this

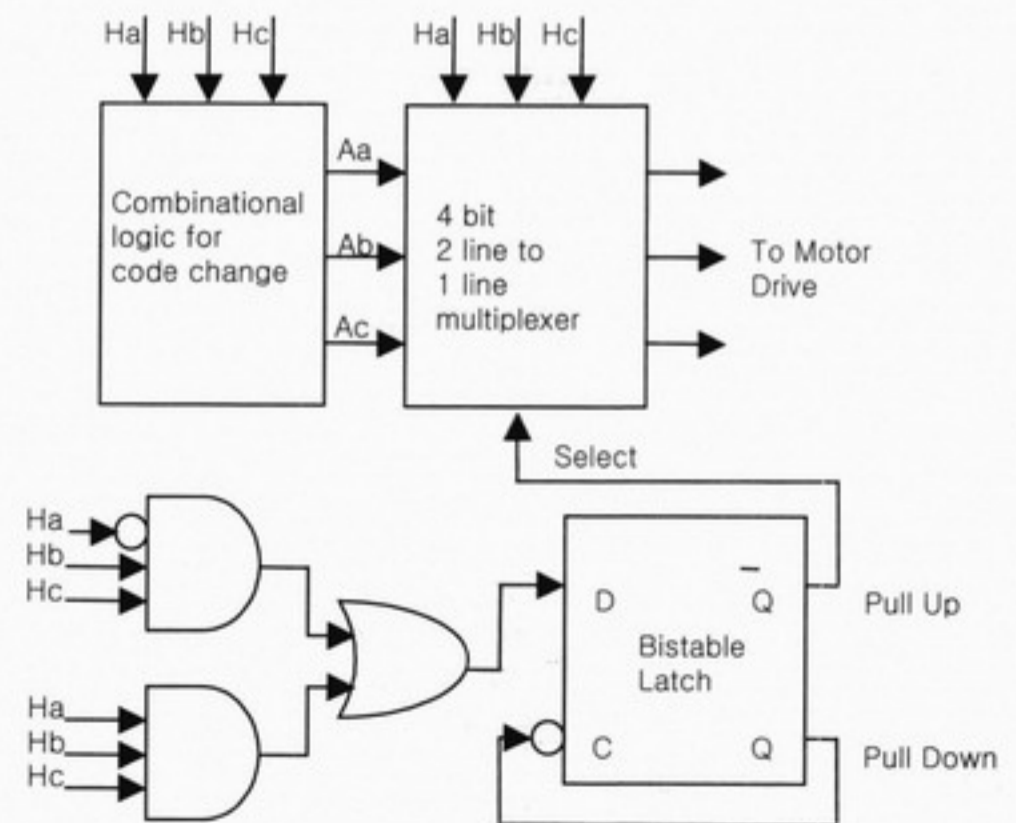

Fig.4 Block diagram of the control circuit for the code change operation

control circuit is summarized as shown in Table 1.

In Table 1, although no clock signal is used in Fig. 4, the notation $Q(t+1)$ is used to indicate the logic state of $Q(t)$ after the logic transition of the bi-stable latch. The rest of the design of the control circuit is explained below. The input D of the bi-stable latch is the output of the logic gates designed to check for the codes 111 or 011 that indicate that the latch type Hall effect sensor is ready for normal operation. If the input D is in logic low state, the input-output condition of the bi-stable latch part is the first row of Table 1 and the select signal which is a logic inverse of $Q(t)$ is in the high state. Similarly, if the input D is in the logic high state, the input-output condition of the bi-stable latch part is the second and third row of Table 1 and the select signal which is a logic inverse of $Q(t)$ is the low state. When the select signal is in the high state, the multiplexer chooses the alternate codes as outputs. Conversely, if the selected signal is in the low state, the multiplexer chooses the codes from the original Hall effect sensor as outputs.

Table 1 Function table for the bi-stable latch of the control circuit

Inputs		Outputs	
D	$Q(t)$	C	$Q(t+1)$
0	0	1	0
1	0	1	1
1	1	0	$Q(t)$

4. Experimental Verification

It is quite difficult to obtain clear experimental waveforms because one can only check the present state of the output waveforms of the sensor. Moreover, the results can simply be obtained by checking whether the BLDC motor runs successfully.

Therefore, to evaluate the proposed fault correction method, starting sequences of the BLDC motor were carried out 20 times. Without the proposed fault correction method, the rate of failure is very frequent; there is a 50% failure rate. If the number of trials were infinite, the

mathematical probability of failure would increase to 66%. Laboratory experiments showed that our proposed fault correction method for latch type Hall effect sensors works for starting up a BLDC motor. Using the proposed fault correction method, in our trials the BLDC motor started 100% of the time. However, for the advance angle of larger than about 15 degrees, unsatisfactory results were observed.

5. Conclusions

A simple and practical fault correction method for rotor position detection of a BLDC motor using a Hall effect latch was presented. The reason why the Hall effect latch unit does not operate properly during startup of a BLDC motor was thoroughly explained. To overcome this problem, a simple and practical code change method was proposed and its hardware implementation issues were explained. The laboratory experiments confirmed that the proposed scheme corrects the latch type Hall effect sensor fault observed during the startup of a BLDC motor. Finally, it should be noted that the fault of the Hall effect sensor discussed in this paper does not stem from any defect in the sensor itself but from the specific mechanical and magnetic structure of the fan cake BLDC motor used in this specific application.

Acknowledgements

This work was supported in part by Kyonggi Institute of Technology and the Ministry of Education & Human Resources Development under the 2004 MOE Financial Support Program.

References

- [1] T. M. Jahns, "Motion Control with Permanent-Magnet AC Machines," Proceedings of the IEEE, vol. 82, no. 8, pp. 1241-1252, August 1994.
- [2] T. J. E. Miller, Brushless PM and Reluctance Motor Drives, Oxford, UK: Clarendon, 1989.
- [3] Hall Effect Latches User's Manual, Worcester, Allegro MicroSystems, Inc., 1995.



In-Cheol Baik was born in Seoul, Korea on February 25, 1962. He received the B.S. degree in electronics from Konkuk University, Seoul, Korea, in 1984 and the M.S. and Ph.D. degrees in Electrical Engineering from the Korea Advanced Institute of Science and Technology (KAIST), Daejeon, Korea, in 1987 and 1998, respectively.

He was a recipient of the University scholarship from Konkuk University during the period of 1980 ~ 1982. From 1987 to February 2003, he worked in the Digital Appliance Research Laboratory of LG Electronics Inc., Seoul, Korea as a Chief Research Engineer where he was responsible for the development of high speed (60,000 rpm) induction and brushless dc motor drive systems for turbo compressor units, compressor drive systems and electronic control circuitry for the system air conditioner outdoor unit, and EMI trouble shooting for the system air conditioner. From February to May 1990, he took the Application Engineer course at SIEMENS Energy & Automation Training Center, Manchester, U.K.

Since March 2003, he has been with the Department of Computer Application Control, at the Kyonggi Institute of Technology, Siheung, Kyonggi-Do, Korea as a faculty member. His current research interests include rotating electrical machine drive systems, electric power conversion systems, microprocessor applications, and control engineering. Dr. Baik is a member of the Korean Institute of Power Electronics (KIPE).



Hyeong-Gil Joo received the B.S. degree from Seoul National University, Seoul, Korea, in 1986, the M.S. degree and the Ph.D degree in Electrical Engineering from KAIST(Korea Advanced Institute of Science and Technology) in 1988 and 2000, respectively. Since 2001, he has been an associate professor in the Department of Mechatronics Engineering at Korea Polytechnic University, Kyeonggi, Korea. His research interests are in the areas of power electronics and control which include motor drive systems, rotating electrical machine design, and power converters. He is a member of KIEE and KIPE.